

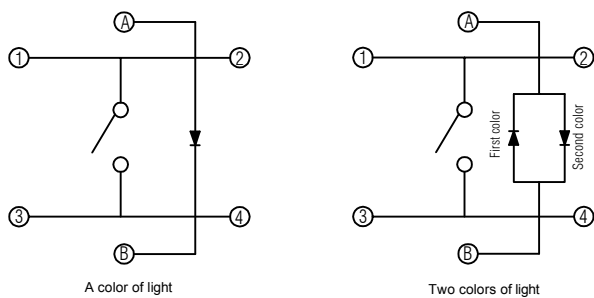

## Switch drawings

Dimensional tolerance is ± 0.2mm

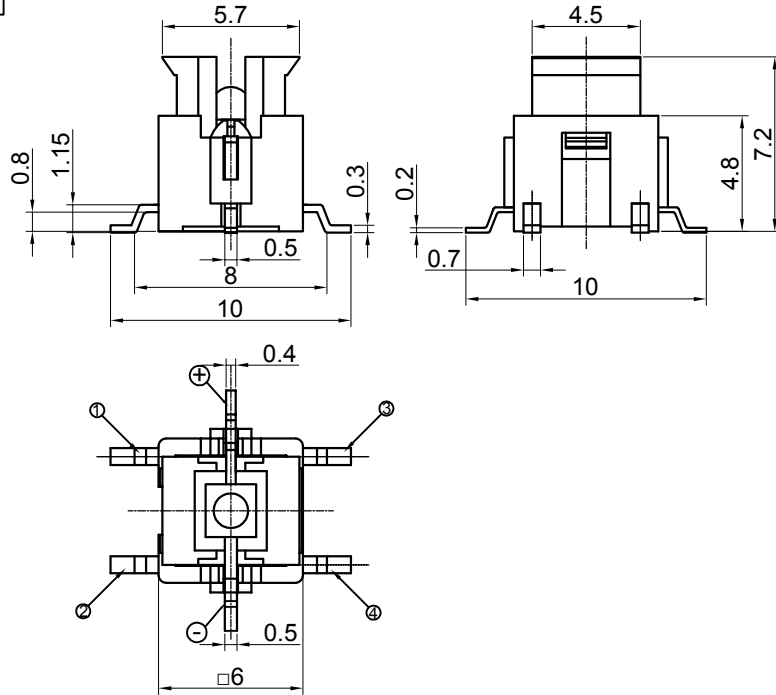

CIRCUIT DIAGRAM

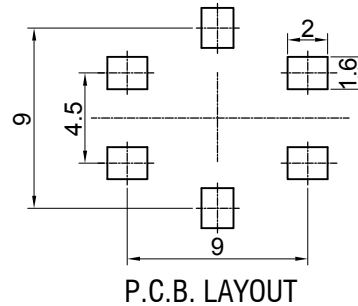

P.C.B. LAYOUT

## Number Description

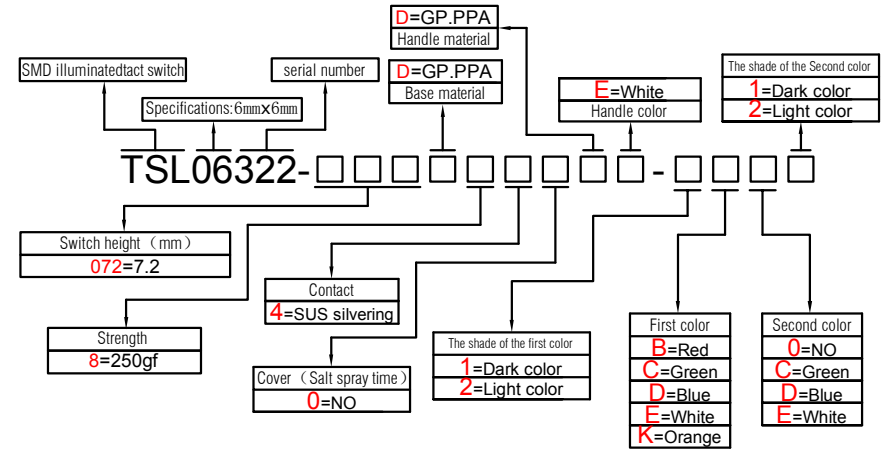

## SPECIFICATIONS

Funtion:	Momentary action
Contact Arrangement:	SPST, Normally Open
Termination:	SMD illuminated

## Environmental

Operating Temperature:	-25 ~ +70 °C
Relative Humidity:	(40 °C) ≤70%

## Electrical

Contact Rating:	50mA 12V DC
Dielectric Strength:	250VAC /1min
Contact Resistance:	100mΩMax.
Insulation Resistance:	100MΩMin.
Travel:	0.25±0.1mm

## Mechanical

Actuation Force:	Optional
Life Expectancy:	Optional

## Materials

1.LED:	Optional
2.Stem:	Optional
3.Contact:	Optional
4.Holder:	Optional
5.Terminal:	Ag plating Au plating

